

RKuV, RKuVF, RKuVL

Vertical plastic pump with cantilever design





Avoid unplanned downtime

The pump is equipped with the i-ALERT®2 sensor as standard. This monitors vibrations and temperature. If preset limit values are exceeded, LEDs in the sensor light up. All measured values can be retrieved via an app or the Ai Platform. This means that necessary measures can be taken in good time before the pump fails.



The RKuV

Optimal for solids

The vertical centrifugal pumps type RKuV and RKuVL have been specially developed to handle aggressive media containing solids respectively crystallising solutions.

Both pump types are also insensitive to dry running and operation against closed discharge valve as there is no sleeve bearing used in the machine.

Metallic fastening elements of the wetted parts (except impeller-shaft connection) are completely omitted. This is one of the design features that demonstrates Rheinhütte's high level of competence in the construction of plastic pumps.

Design features

- Design: vertical, single-stage
- Construction: cantilever design
- Casing design: single or double volute casing
- Pump installation: wet
- Bearing lubrication: grease lubrication
- Installation versions:
 - sole plate on tank or steel structure
- Ambient temperature: -20 °C to +40 °C
- Max. solid content: ca. 30 %



Technical data

	RKuV	RKuVL
Size DN	32 to 200	32
Q_{\max} (m ³ /h)	450	10
H_{\max} (m)	60	35
Submersion depth _{max} (m)	1,8	0,5
Temperature (°C)	-40 to +100	-40 to +60
Standards	ISO 5199	
Flange motor design	Option	-
Closed impeller	-	-
Open impeller	Standard	Standard
Vortex impeller	RKuVF	-
Seal	Labyrinth seal, Lip ring seal	

Options

- Bearing temperature and vibration monitoring
- Flange processing in line with international standards
- Suction tube and / or suction strainer design
- Pump accessories

Fields of application

- Acids
- Alkalis
- Chemical industry
- Condensates
- Corrosive media
- Sludges
- Sump pump
- Suspensions
- Wastewater

Lip ring seal

Sealed by dry-running or shaft seal rings

Labyrinth seal

Contact-free seal for non-pressurised container systems

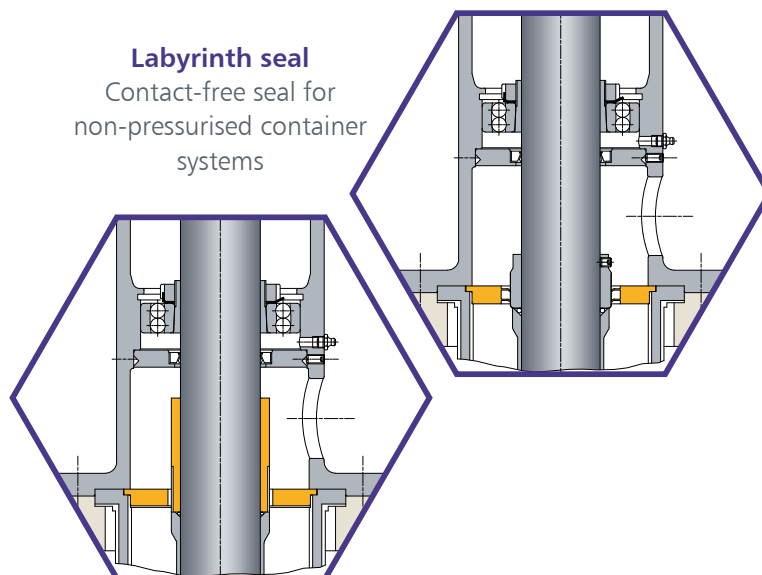

Main features

RKuV

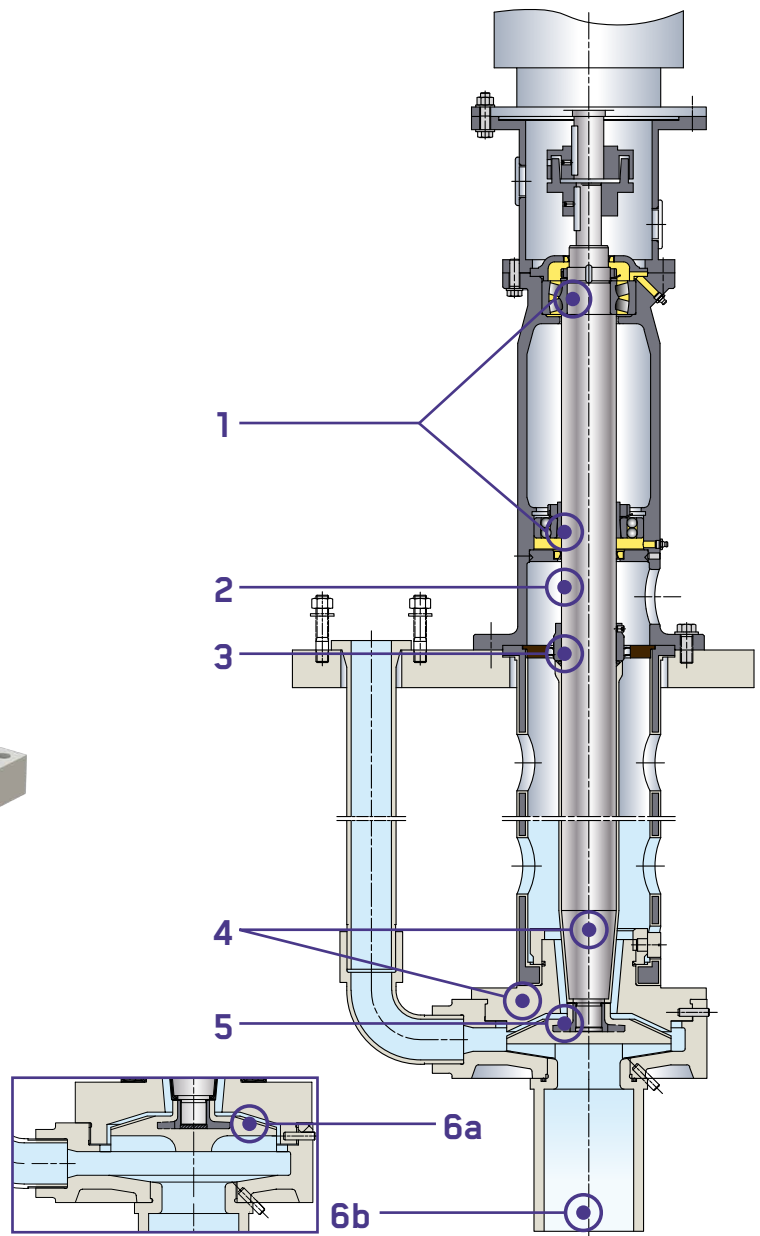

1 Transmission of hydraulic forces via heavy-duty shaft and industrial roller bearings.

2 Due to the large distance between the shaft sealing and bearings, the rolling bearings are protected against chemical steams and damage.

3 Sealing of shaft against the atmosphere by means of maintenance-free labyrinth or lip seal.

4 Metal-free design: Up to DN 150, hydraulic parts form-fit connected without metallic screw connections. Steel rubberized suspension tube and shaft.

5 Cantilever design for media containing solids. Long operating times due to minimized wear and tear and low risk of clogging.

6 Options
 a.) Free flow design for use with large solid particles.
 b.) Suction pipe and suction strainer optionally available in extended version.

The drawings essentially correspond to the execution. We reserve the right to make design changes. Other designs on request.

RKuVL

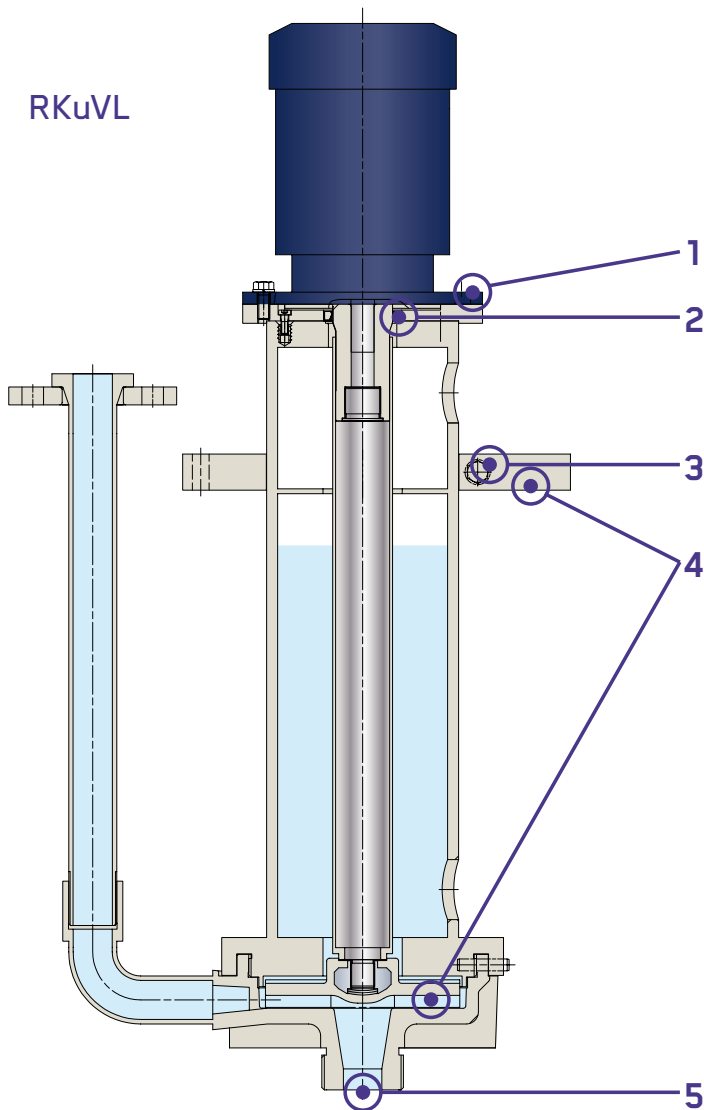

1 Cost-effective and compact design due to flange motor.

2 The sealing to the motor bearing is affected by a maintenance-free lip ring seal.

3 Due to the height-adjustable mounting flange, the immersion depth is freely selectable between 300 and 500 mm.

4 Parts in contact with the medium and support flange made of plastic PP or PVDF.

5 In the case of coarse solids impurities, a strainer can be fitted on the suction side, for which the mesh size is matched to the free through passage of the impeller respectively casing.

Pumps & installation dimensions

Size	BB	Sole plate				Installation opening		N2
		g ^{Ku}	g ^{ST/Ku}	A	C	Length	Depth	
RKuVL 32/160	2	30	-	300	300	380	240	32
32/160	2	50	-	490	370	390	270	32
32/200	2	50	-	530	390	450	320	32
40/160	2	50	-	510	370	430	290	40
40/250	2	50	-	640	500	540	410	40
50/200	2	50	-	590	420	510	340	50
50/315	2	50	-	760	580	660	480	50
65/160	2	50	-	610	430	530	350	65
65/250	2	50	-	710	510	610	410	65
80/200	2	50	-	710	500	630	420	80
80/250	2	-	21	840	570	740	470	80
80/315	2	-	21	850	590	750	490	80
80/400	4	-	28	950	750	850	650	80
100/250	4	-	28	850	590	750	490	100
125/315	4	-	28	1000	700	900	600	125
125/400	4	-	28	1080	800	980	700	125
150/315	4	-	28	1150	700	1045	600	150
150/400	4	-	28	1240	780	1140	680	150
200/315	4	-	28	1400	800	1300	700	200

Submersion depth

RKuV / RKuVF 500, 1000, 1500 mm

RKuVL 300 bis 500 mm

X Max. 2000 mm (suction tube/strainer optional)

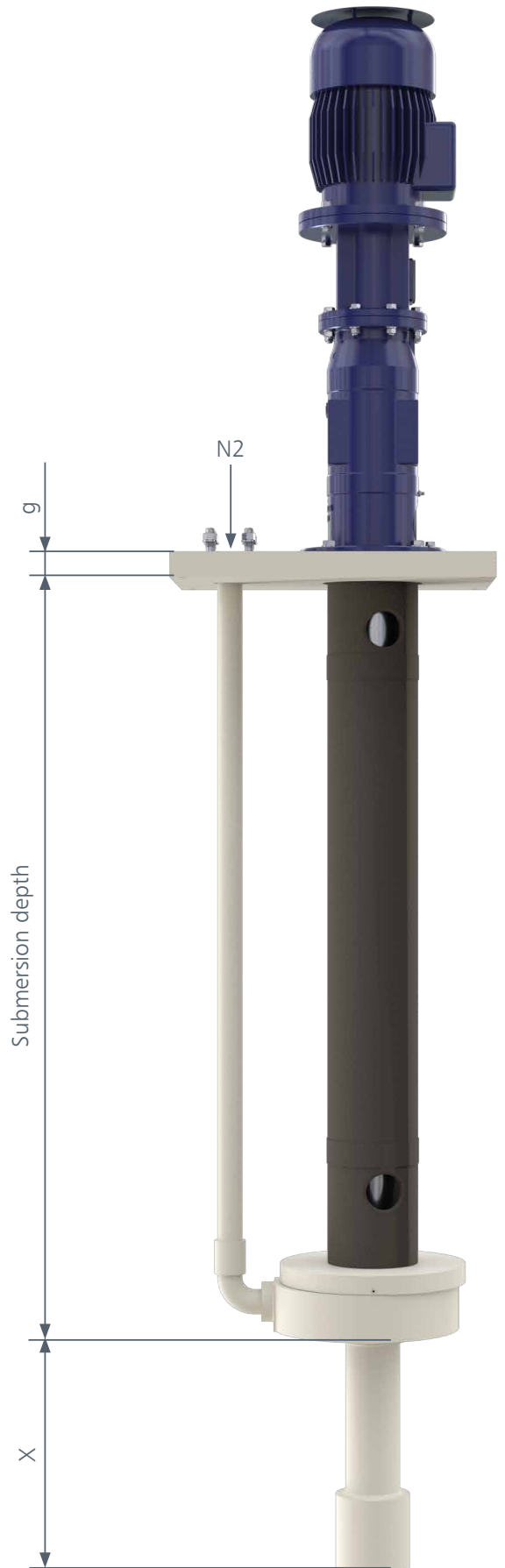
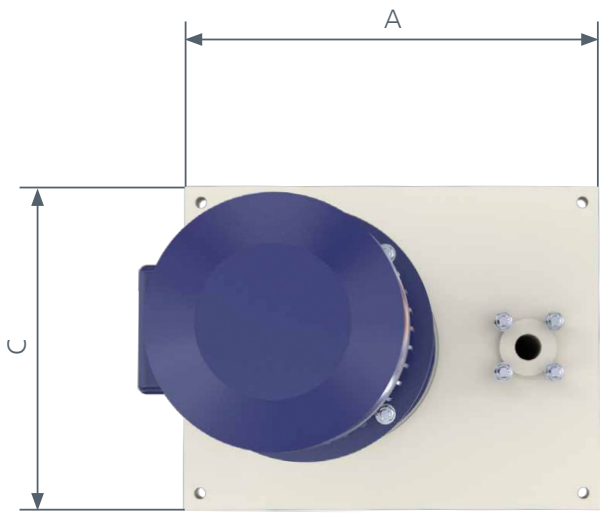

Capacity ranges

RKuV/RKuVL : 50 Hz n = 1450 /min

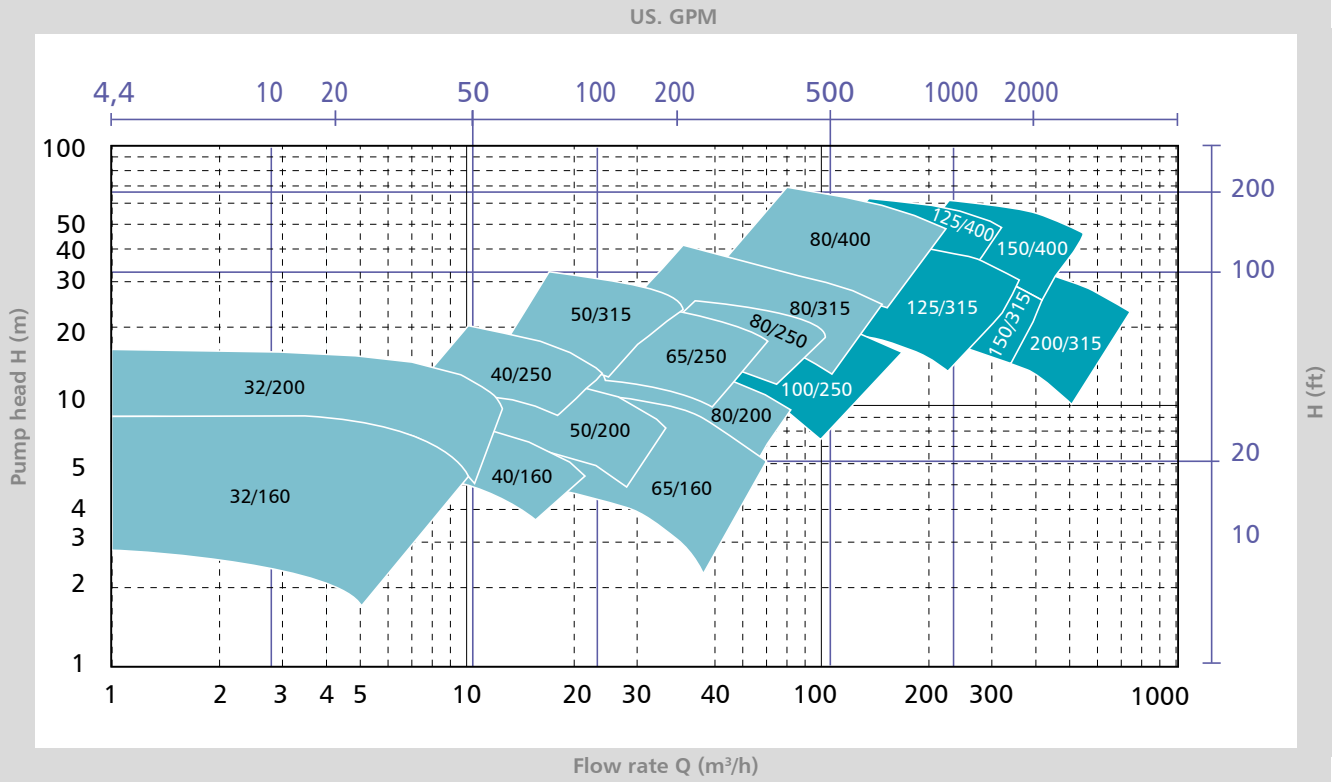

RKuVF : 50 Hz n = 1450 /min

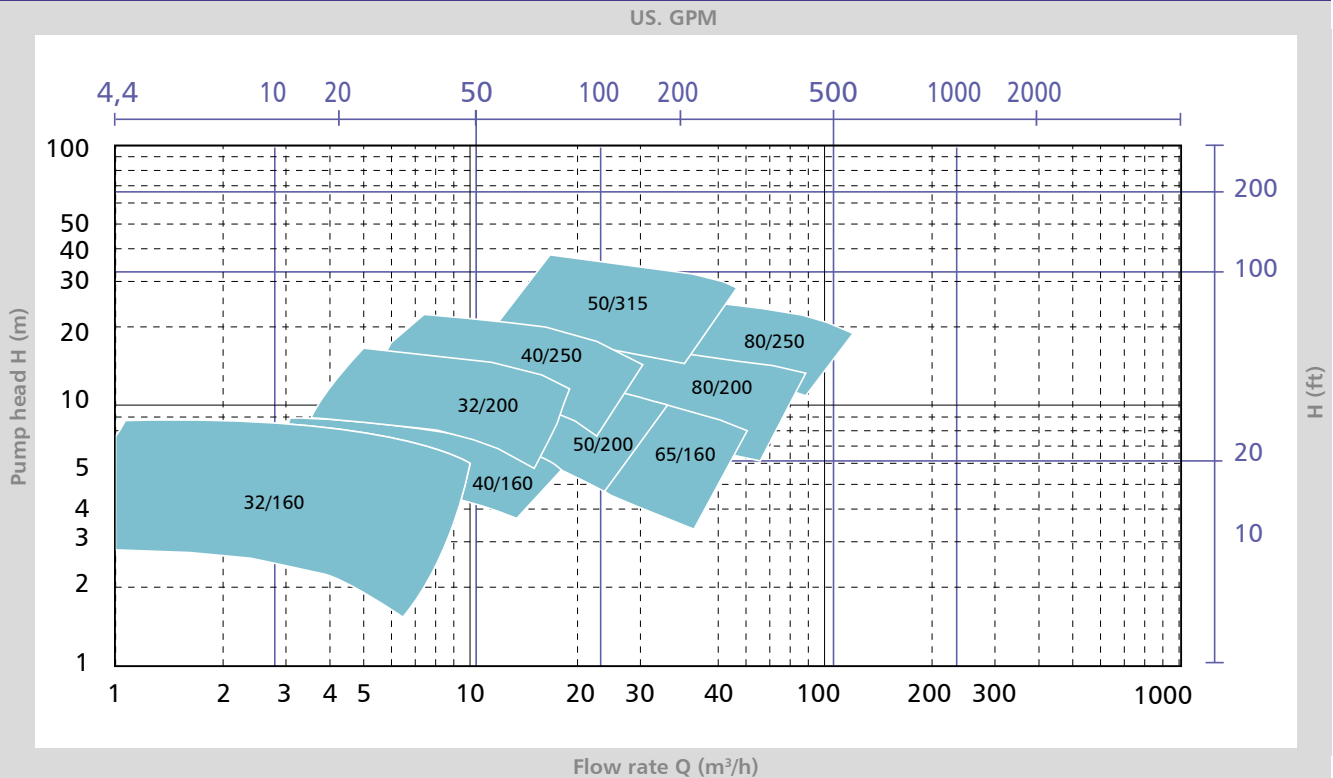

Bearing bracket 2 4

RKuV/RKuVL : 50 Hz n = 2900 /min

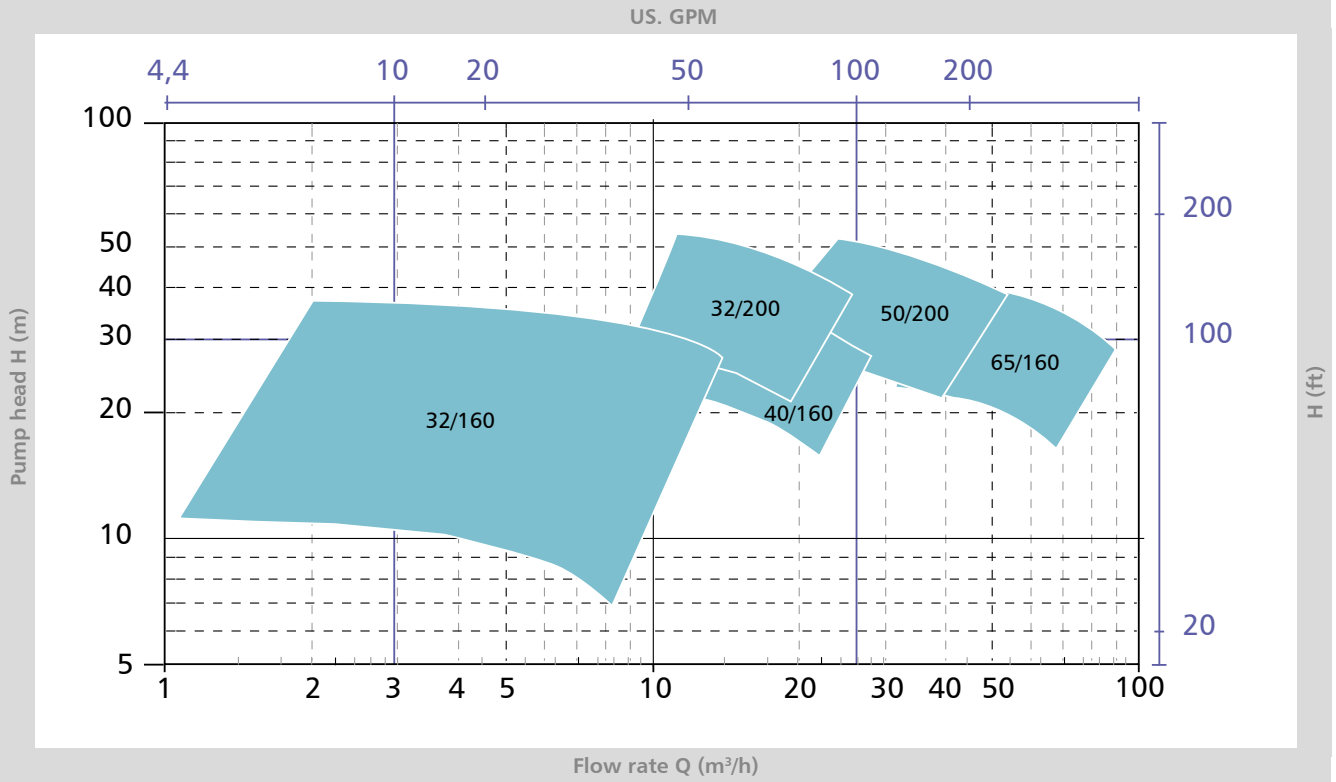

RKuVF : 50 Hz n = 2900 /min

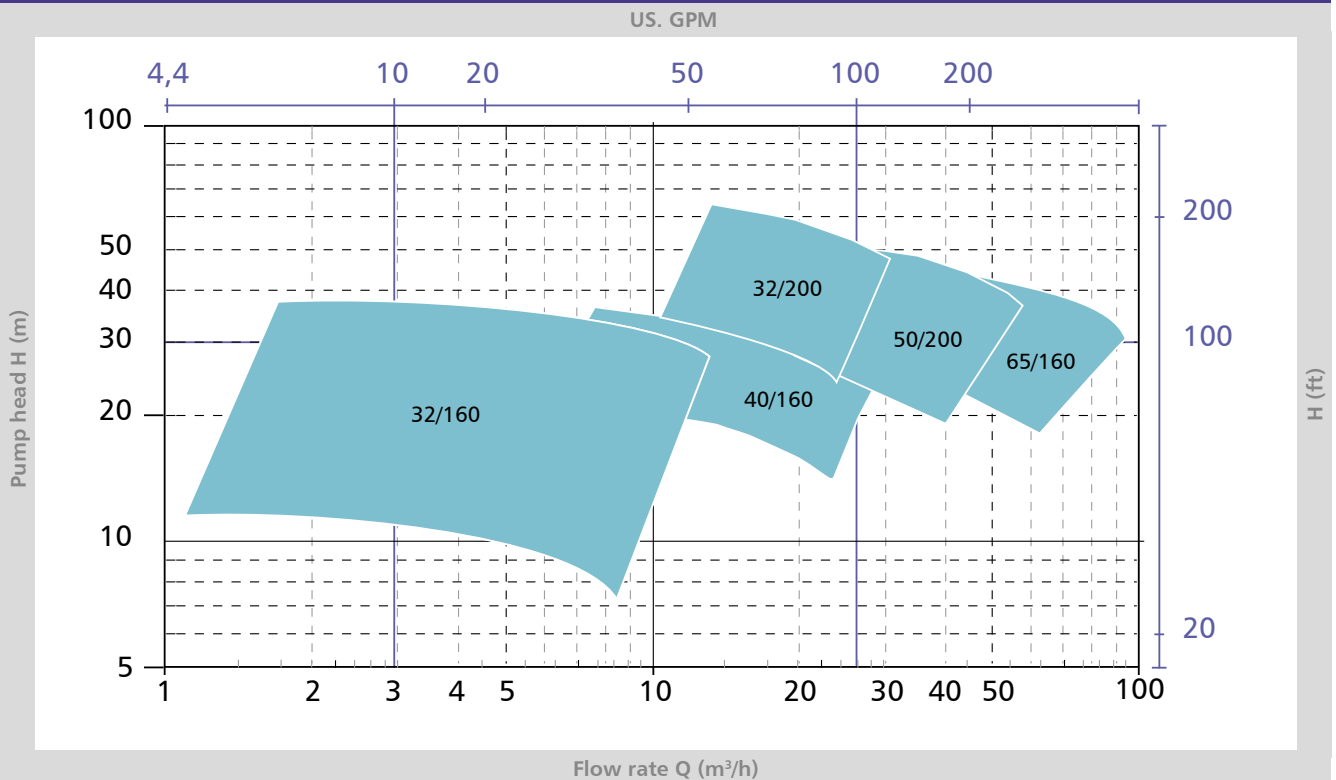

Capacity ranges

RKuV/RKuVL : 60 Hz n = 1750 /min

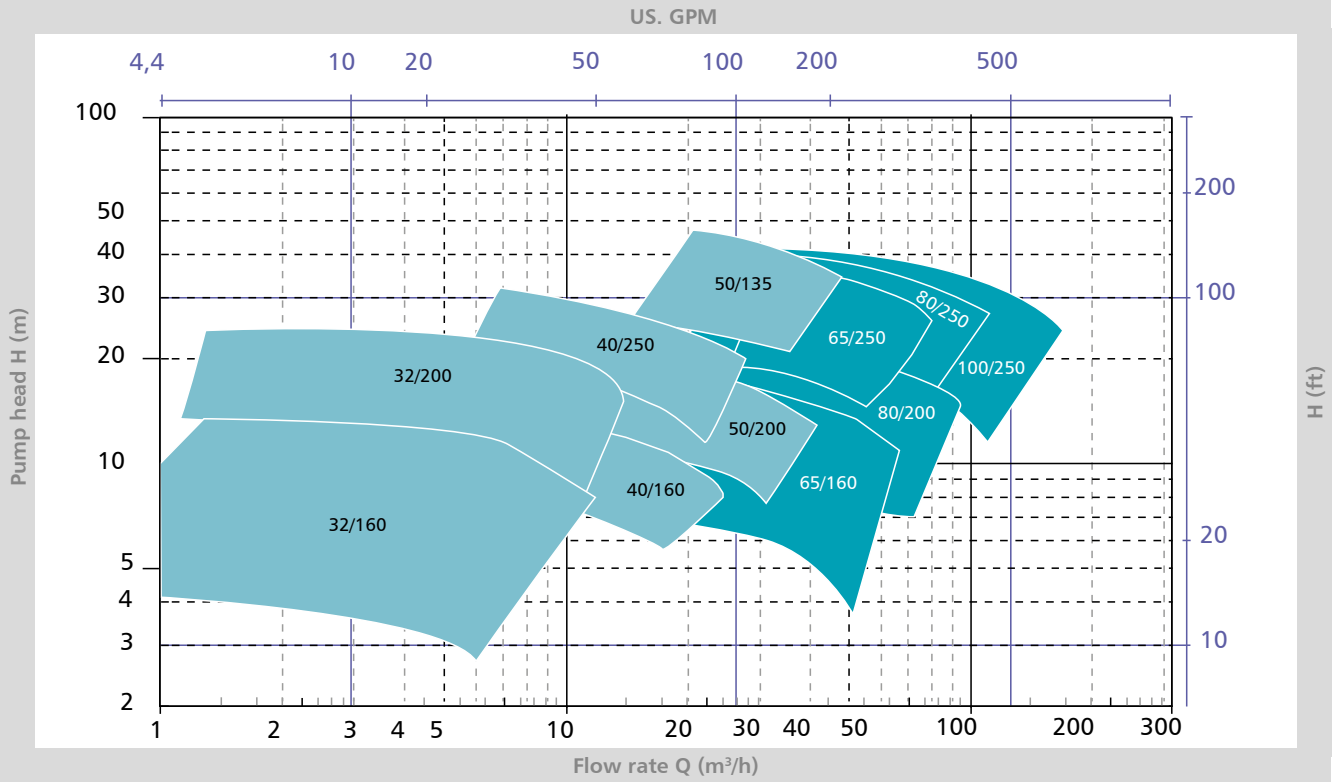

RKuVF : 60 Hz n = 1750 /min

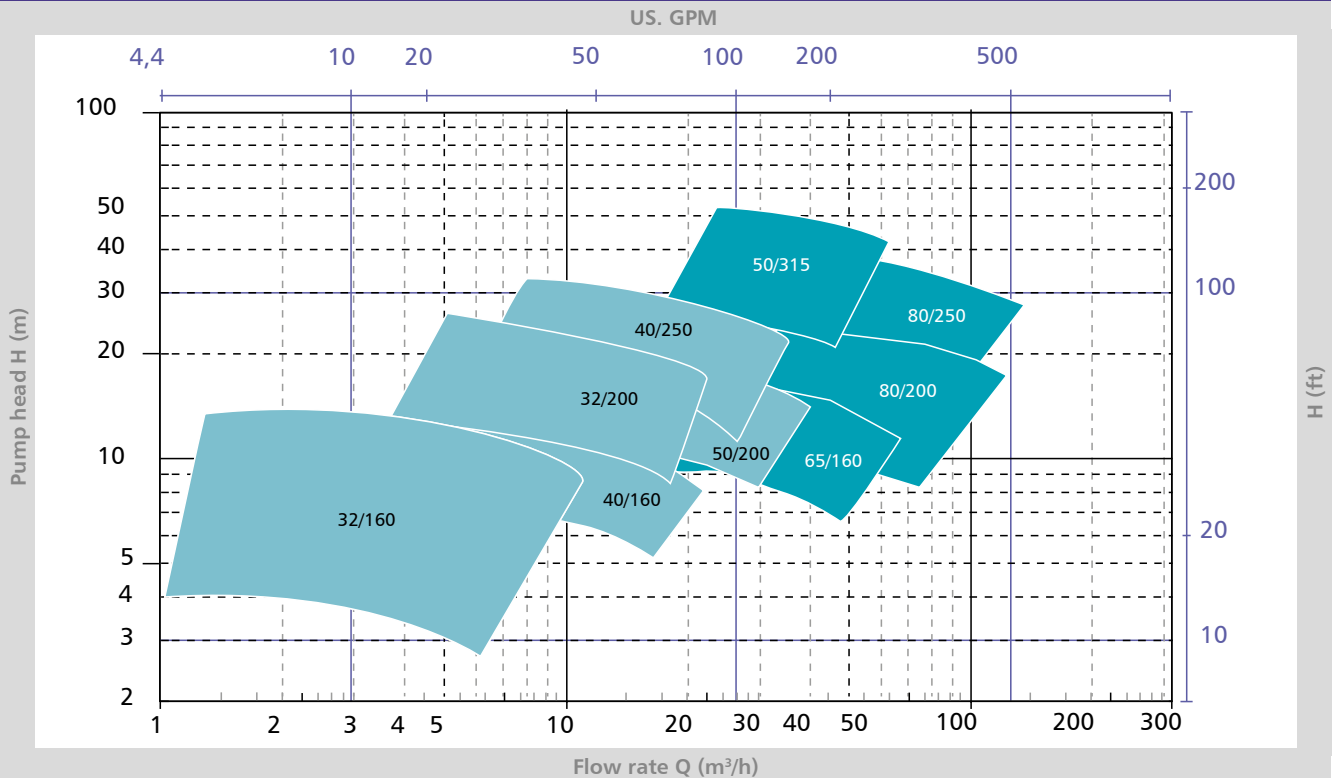

Bearing bracket **2** **4**

Variable plastic materials

The chemical centrifugal pumps RKuV and RKuVL are available as standard in four different plastics. Our material experts help you to choose the right material. Plastics are in particular demand in applications with high corrosion resistance requirements, in order to ensure a long pump life cycle.

PP – Polypropylene

This plastic is particularly suitable for simple, common applications. It offers outstanding performance at temperatures from 0 to +80°C. PP has proven its worth in acids, alkalis and saline solutions as well as in hydrochloric acid pickling.

PE 1000 (UHMWPE) – Polyethylene

The outstanding feature of this high molecular weight polymer is its resistance to wear in case of solids in the pumped medium. There is also a wide range of corrosion resistance options. In the temperature range from -20 to +70°C, PE 1000 is in many cases an alternative to stainless steels.

PVDF – Polyvinylidene fluoride

The partial fluorination of this polymer increases its chemical resistance many times over. PVDF is resistant to most solvents, acids and oxidants. PVDF is an optimum material for many applications in the chemical industry for temperatures from -20 to +100°C.





— An ITT Brand

ITT RHEINHÜTTE Pumpen GmbH
Rheingaustraße 96-98
D-65203 Wiesbaden
T +49 611 604-0
info@rheinhuette.de
www.rheinhuette.de