

CPDR & RCNKu

Horizontal plastic pump

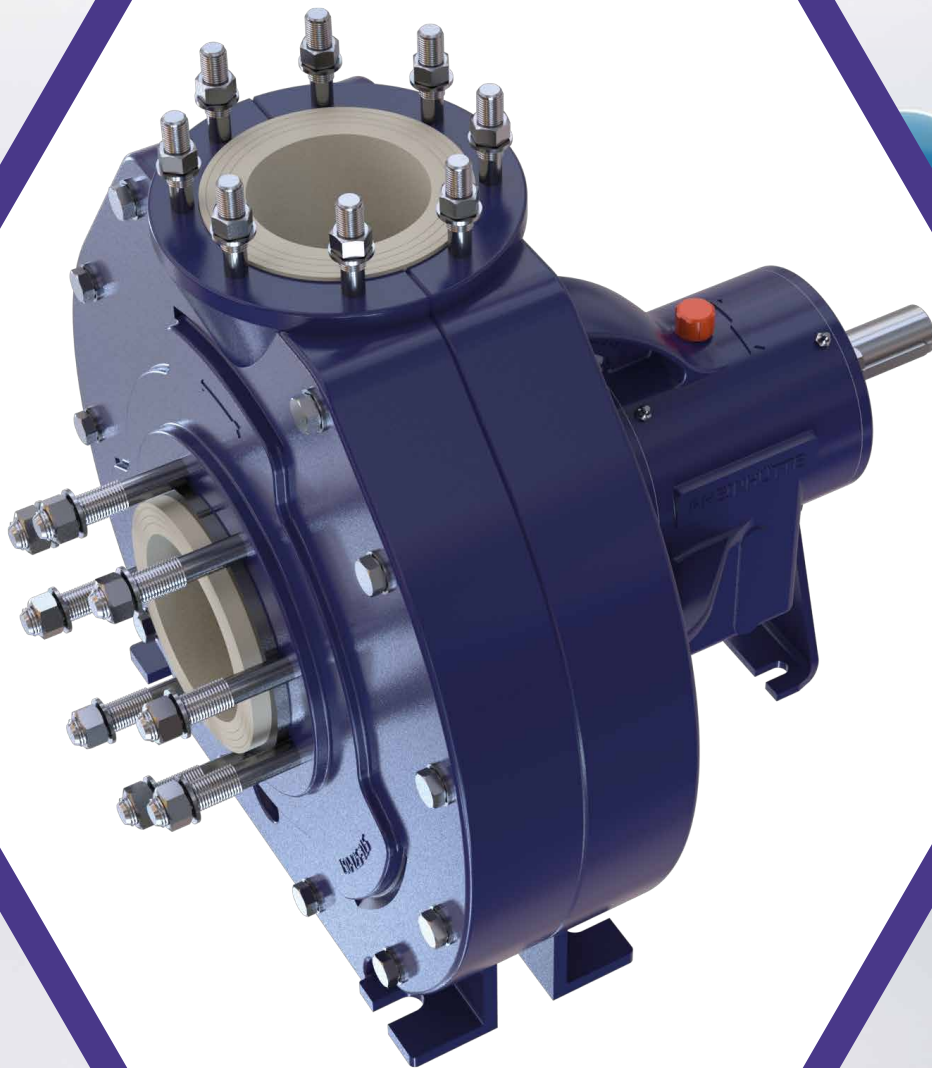



CPDR & RCNKu

A versatile standard series

Small and large – CPDR and RCNKu. The two types differ from each other in their detailed design and manufacture. Materials and sealings are the same.

Conveyance requirements can be flexibly and economically met with a wide range of 21 different pump sizes with capacities of up to 2,500 m³/h.

The pump size and material will be specifically selected to meet your requirements. Flow -optimised hydraulic systems ensure efficiency and economy. Rheinhütte plastic pumps are available in six different materials.

Rheinhütte plastic pumps are standard pumps and can therefore replace other standard chemical pumps of the same size.

We can also offer you customised fluid conveyance equipment outside the standard which is designed for your particular conveyance requirement - increased efficiency with the same pump size.

Design features

- Design: horizontal, single-stage
- Construction: back-pull-out design according to ISO 2858
- Casing design: single volute casing
- Bearing lubrication: oil or grease lubrication
- Installation versions: Base frame welded or base plate cast
- Temperature range: -20 °C to +60 °C (-4 °F to +140 °F)
- Max. solids content: approx. 5 % (with free flow design approx. 30 %)

Optionen

- Drain of volute casing
- Flushing of the mechanical seal in different versions
- Temperature and vibration monitoring
- Equipment health monitoring with patented i-Alert®2
- Flange processing in line with international standards
- Thermosyphon system
- Quench system
- Pump accessories



Technical data

| | CPDR | RCNku |
|--|------------------------------|---------------|
| Size DN | 32 to 80 | 80 to 400 |
| Q _{max} m ³ /h (gpm) | 200 (881) | 2.500 (11007) |
| H _{max} m (ft) | 100 (328) | 100 (328) |
| Temperature °C (°F) | -30 to +190 (-22 to 374) | |
| Normen | EN 22858, ISO 2858, ISO 5199 | |
| Open impeller | Standard | - |
| Closed impeller | - | Standard |
| Vortex impeller | CPRF | RCFKu |
| Flange motor design | CPDRB | - |
| Seal | Mechanical seal | |

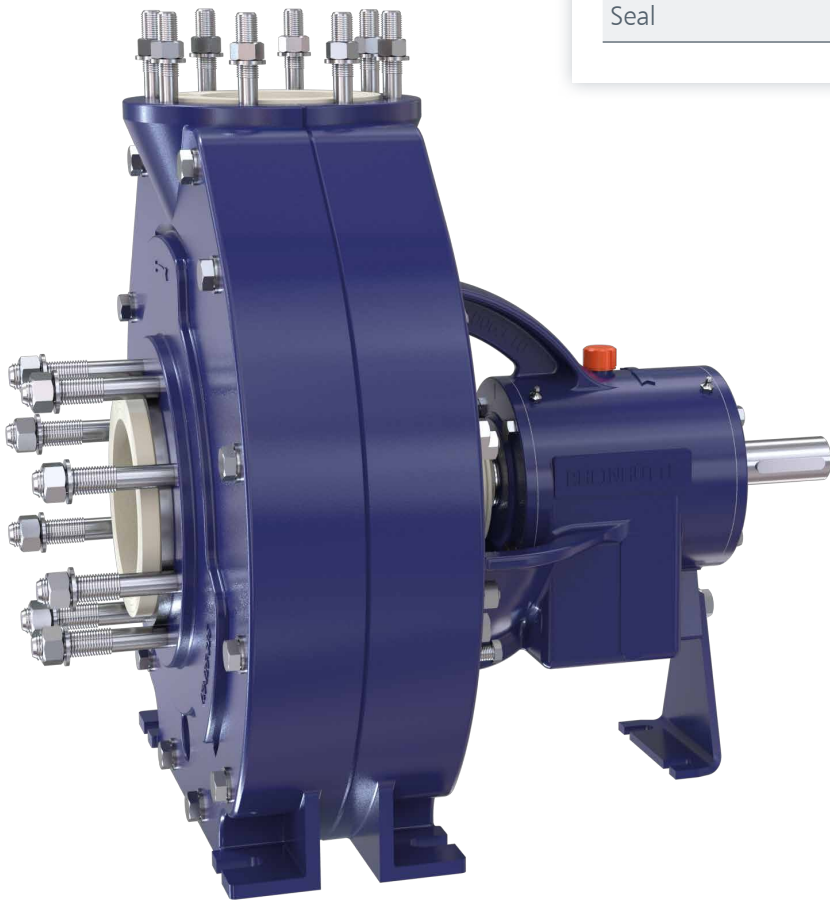

Typical applications

- Chemical waste water
- Chloralkali electrolysis
- Fertilizer production
- Seawater
- Flue gas scrubber (waste incinerators)
- Brine
- Hydrochloric acid
- Sulphuric acid
- Steel industry
- Scrubber

Main features

CPDR & RCNKu

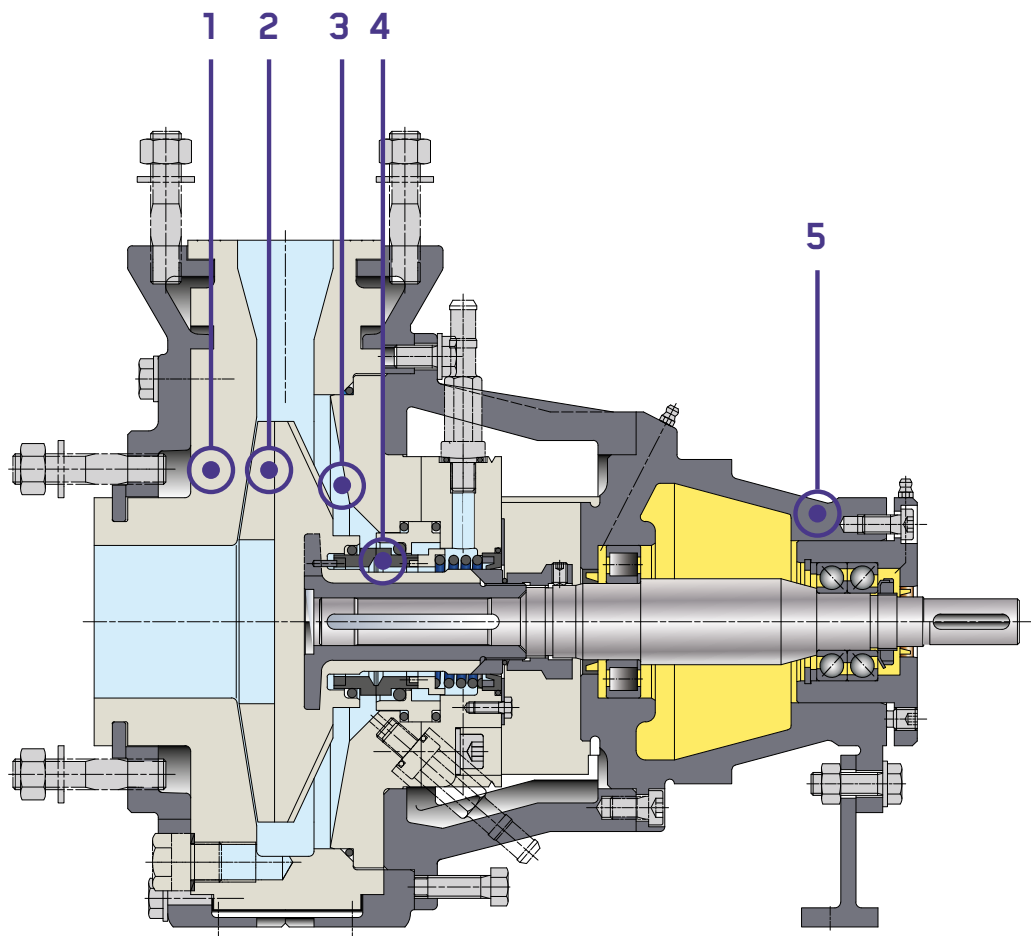

1

The process-oriented design enables wearing parts to be quickly and easily replaced.

3

Seals optimised for their flow and wear characteristics enable the pumps to convey media containing up to 5 % solids and for the free flow design (page 5) even up to 30 %.

2

Large volumes of solids, gaseous components, fibres and gross contaminants prohibit the use of rotary pumps. But vortex pumps meet this conveyance challenge without problems. The impeller is only indirectly involved in accelerating the medium, leading to a corresponding reduction in wear. Toleration of even gaseous components in the fluid to be pumped is significantly enhanced. Large passage widths allow more operating reliability.

4

Mechanical seal concept that is suitable for crystallizing, hot or solids bearing media. An optimised design ensures that seals can be easily installed and removed and are economic in use.

5

A robust bearing bracket ensures only minor deflection on the shaft and a long working life for the roller bearings and the mechanical seal – even when working at the limit of its capability.

The drawings essentially correspond to the execution. We reserve the right to make design changes.

Avoid unplanned downtime

The RCNku is equipped with the i-ALERT®2 sensor as standard. This monitors vibrations and temperature. If preset limit values are exceeded, LEDs in the sensor light up. All measured values can be retrieved via an app or the Ai Platform. This means that necessary measures can be taken in good time before the pump fails.

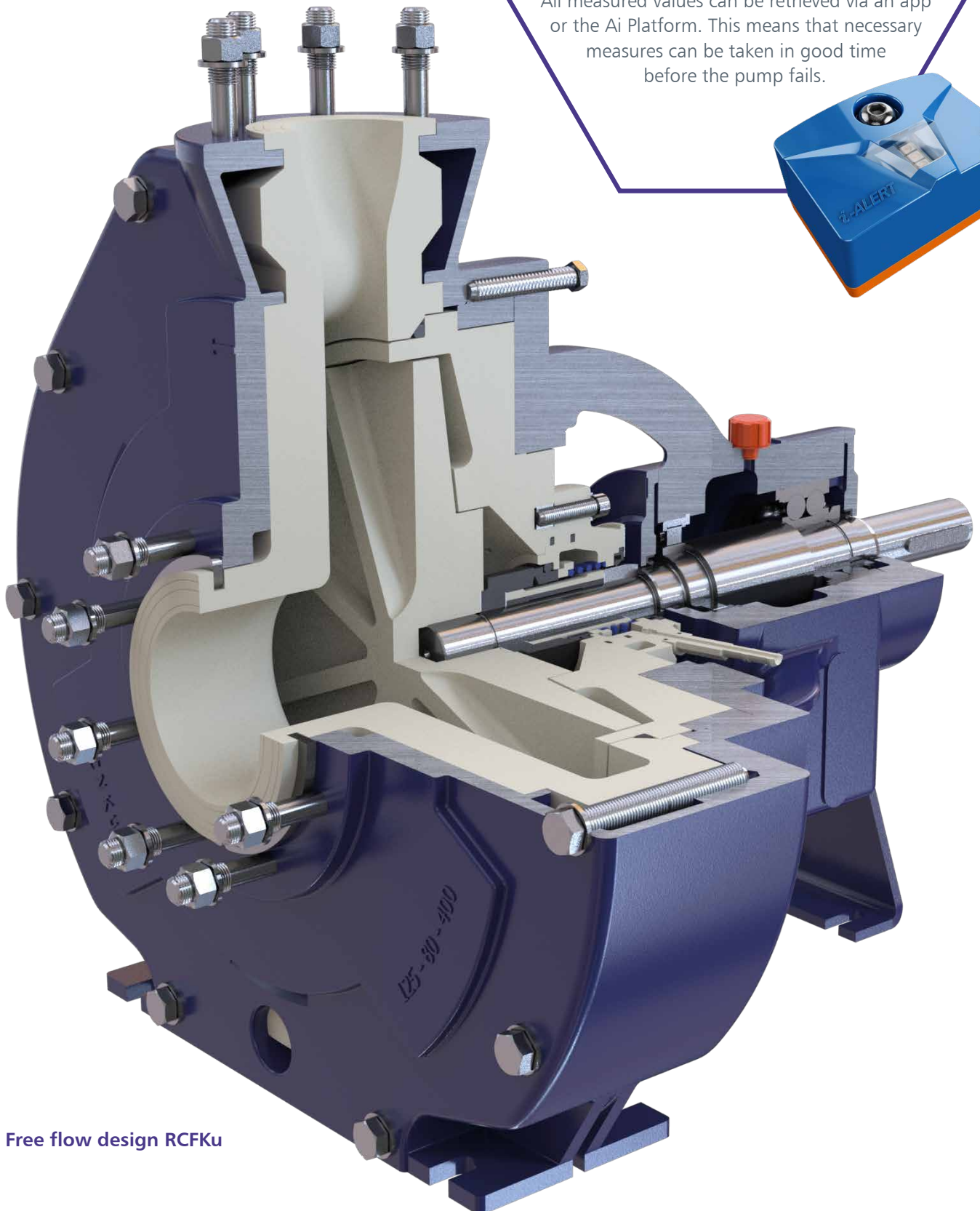

Free flow design RCFKu

Mechanical seal

Optimal for aggressive media through customized design

The design of pump and mechanical seal must be matched to a particular measure. Flow-optimised free-spaces and channels must precisely fit the seals and individual flushing concepts. Only by taking this approach is it possible to avoid the adverse effects of large volumes of solids or crystallising or adhesive media on the seal. The advanced

CS (single-acting) and CST (double-acting) seal designs of the Rheinhütte plastic pumps make operations safe and maintenance simple – for an economic standardised chemical pump. Various flushing variants are available as an option.

CPDR with single mechanical seal (CS)

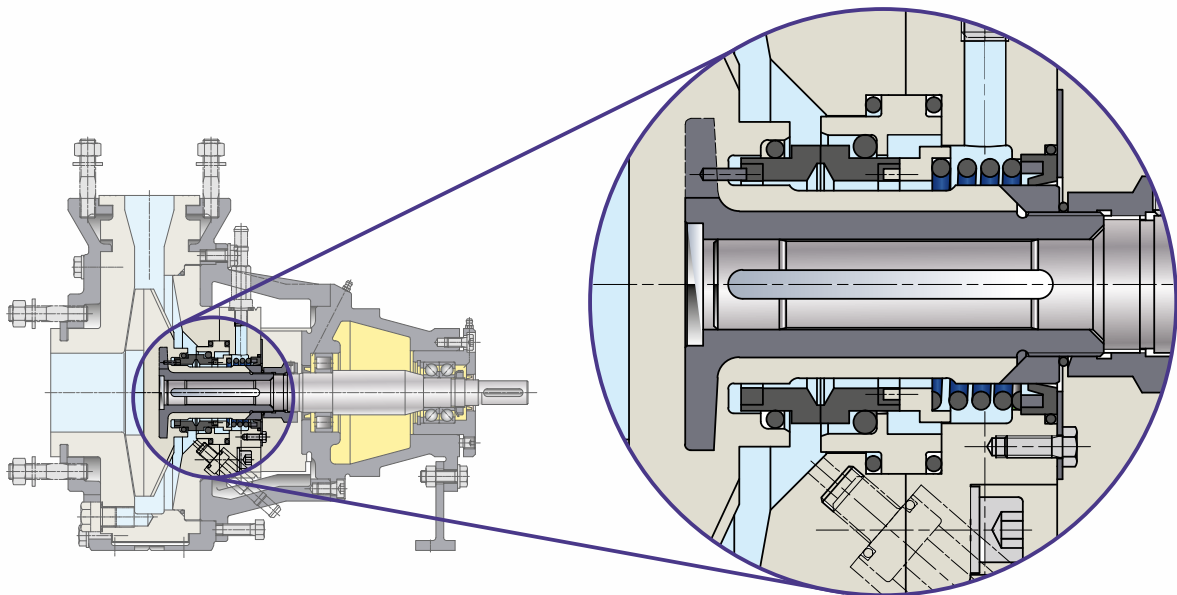

The drawings essentially correspond to the execution. We reserve the right to make design changes.

RCNku with double mechanical seal (CST)

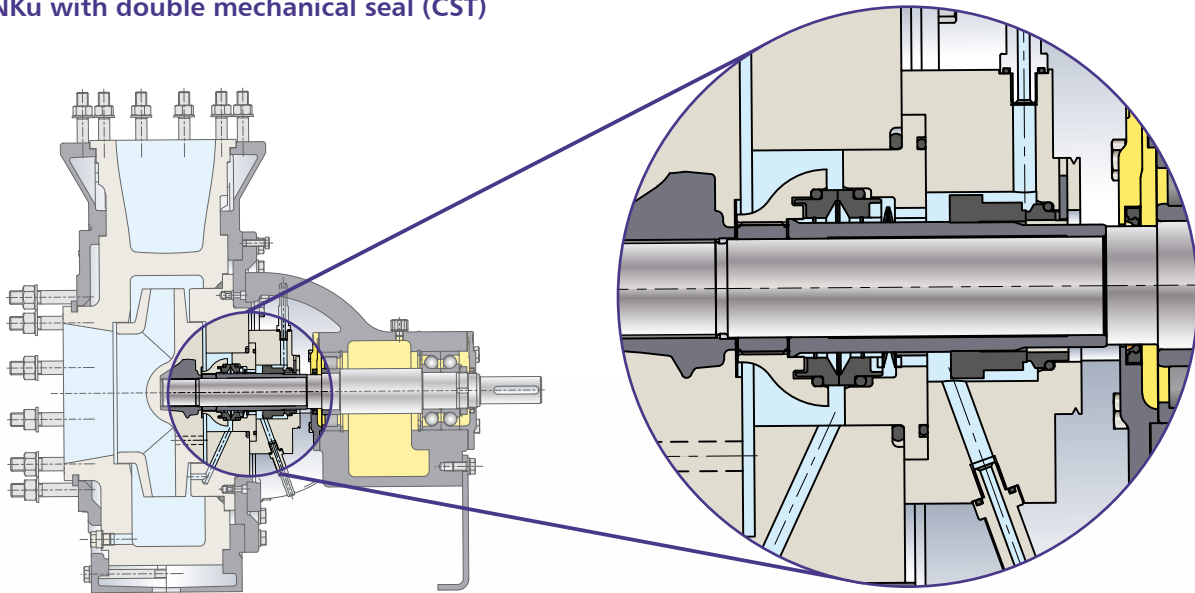

Durable through coordinated design

The design of the seal relocates all susceptible components to a protected stationary position – on the outside. Thus springs and O-rings can operate in the best possible environment free from the effect of the medium and the rotation of the shaft.

Service-friendly due to limited number of parts

The bearing ring and the counter ring, the main components of the mechanical shaft seal are identical in construction. They can be purchased separately, this avoiding confusion during maintenance. The design of the seal always causes the optimal closing pressure to act on both rings during operation, making the seals highly effective and the wear slight.

Plastic materials

Our material experts help you to choose the right material. Plastics are in particular demand in applications with high corrosion resistance requirements, in order to ensure a long pump life cycle.

PP – Polypropylene

This plastic is particularly suitable for simple, common applications. It offers outstanding performance at temperatures from 0 to 100 °C. PP has proven its worth in acids, alkalis and saline solutions as well as in hydrochloric acid pickling.

PE 1000 (UHMWPE) – Polyethylene

The outstanding feature of this high molecular weight polymer is its resistance to wear in case of solids in the pumped medium. There is also a wide range of corrosion resistance options.

In the temperature range from -50 to +80 °C, PE 1000 is in many cases an alternative to stainless steels.

PE 1000R – Polyethylene

PE 1000R is a further development of the standard polyethylene PE 1000 with wear-minimising additives for up to 30% higher durability - for use in highly abrasive suspensions with process-related critical solids content. The material can be used at temperatures from -50 to +80 °C.

PVDF – Polyvinylidene fluoride

The partial fluorination of this polymer increases its chemical resistance many times over. PVDF is resistant to most solvents, acids and oxidants. PVDF is an optimum material for many applications in the chemical industry for temperatures from -20 to 130 °C.

PTFE – Polytetrafluoroethylene

PTFE shows an outstanding resistance against nearly all organic and inorganic media over a wide temperature range. Centrifugal pumps made of PTFE can be used between -50 °C and 180 °C.



Pumps & installation dimensions

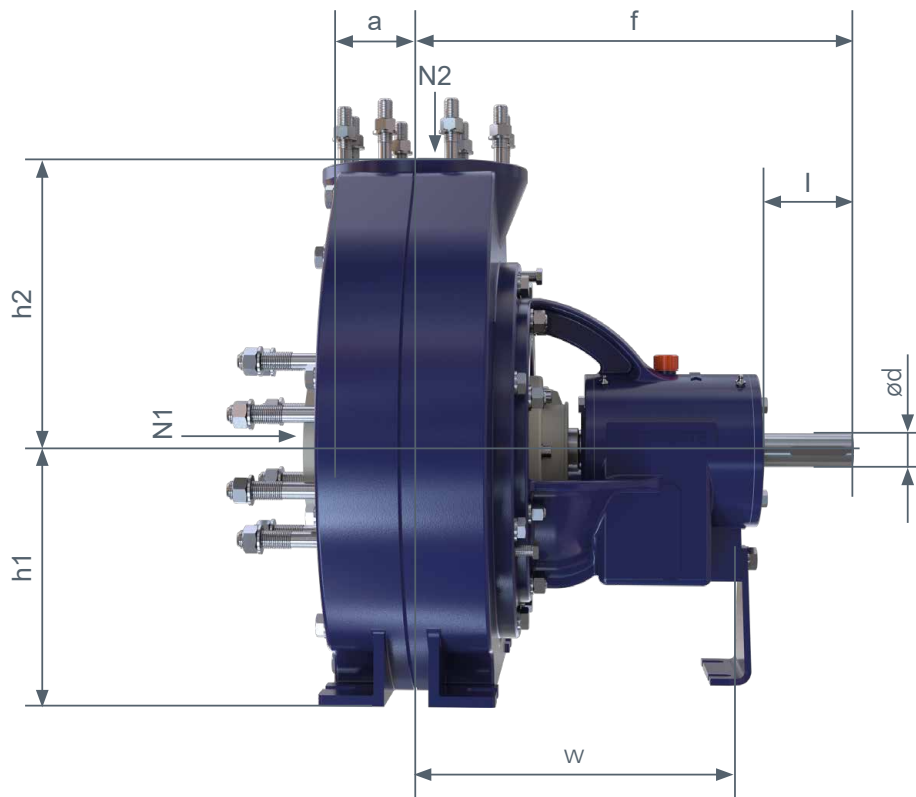

| Size | | BB | Pump dimensions | | | | Base dimensions | Shaft end | | Flange dimensions | |
|-------------|-------|----|-----------------|------|-------|-------|-----------------|-----------|-----------------|-------------------|-----|
| | | | a | f | h_1 | h_2 | | w | $\varnothing d$ | l | N2 |
| 50-32-160 | CPDR | 1 | 80 | 385 | 132 | 160 | 285 | 24 | 50 | 32 | 50 |
| 50-32-200 | CPDR | 1 | 80 | 385 | 160 | 180 | 285 | 24 | 50 | 32 | 50 |
| 80-65-160 | CPDR | 1 | 100 | 385 | 160 | 180 | 285 | 24 | 50 | 65 | 80 |
| 80-50-200 | CPDR | 1 | 100 | 385 | 160 | 200 | 285 | 24 | 50 | 50 | 80 |
| 65-40-250 | CPDR | 2 | 100 | 500 | 180 | 225 | 370 | 32 | 80 | 40 | 65 |
| 80-50-315 | CPDR | 2 | 125 | 500 | 225 | 280 | 370 | 32 | 80 | 50 | 80 |
| 100-80-160 | CPDR | 2 | 100 | 500 | 160 | 200 | 370 | 32 | 80 | 80 | 100 |
| 100-65-250 | CPDR | 2 | 125 | 500 | 200 | 250 | 370 | 32 | 80 | 65 | 100 |
| 125-80-200 | CPDR | 2 | 125 | 500 | 180 | 250 | 370 | 32 | 80 | 80 | 125 |
| 125-80-250 | RCNKu | 2 | 125 | 500 | 225 | 280 | 370 | 32 | 80 | 80 | 125 |
| 125-80-315 | RCNKu | 3 | 125 | 530 | 250 | 315 | 370 | 42 | 110 | 80 | 125 |
| 125-80-400 | RCNKu | 3 | 125 | 530 | 280 | 355 | 370 | 42 | 110 | 80 | 125 |
| 125-100-250 | RCNKu | 3 | 140 | 530 | 225 | 280 | 370 | 42 | 110 | 100 | 125 |
| 150-125-315 | RCNKu | 3 | 140 | 530 | 280 | 355 | 370 | 42 | 110 | 125 | 150 |
| 150-125-400 | RCNKu | 3 | 140 | 530 | 315 | 400 | 370 | 42 | 110 | 125 | 150 |
| 200-150-400 | RCNKu | 4 | 160 | 670 | 315 | 450 | 500 | 48 | 110 | 150 | 200 |
| 250-200-315 | RCNKu | 4 | 180 | 670 | 355 | 450 | 500 | 48 | 110 | 200 | 250 |
| 250-200-400 | RCNKu | 4 | 180 | 670 | 355 | 500 | 500 | 48 | 110 | 200 | 250 |
| 300-250-500 | RCNKu | 6 | 250 | 935 | 475 | 670 | 680 | 75 | 150 | 250 | 300 |
| 350-300-400 | RCNKu | 6 | 300 | 935 | 500 | 670 | 680 | 75 | 150 | 300 | 350 |
| 400-400-600 | RCNKu | 7 | 340 | 1160 | 700 | 550 | 900 | 100 | 180 | 400 | 400 |

BB = Bearing bracket N1 = Suction flange N2 = Pressure flange

All dimensions are shown in millimetres.

Capacity ranges

CPDR/RCNku : 50 Hz

n = 1450 /min

*n = 980 /min

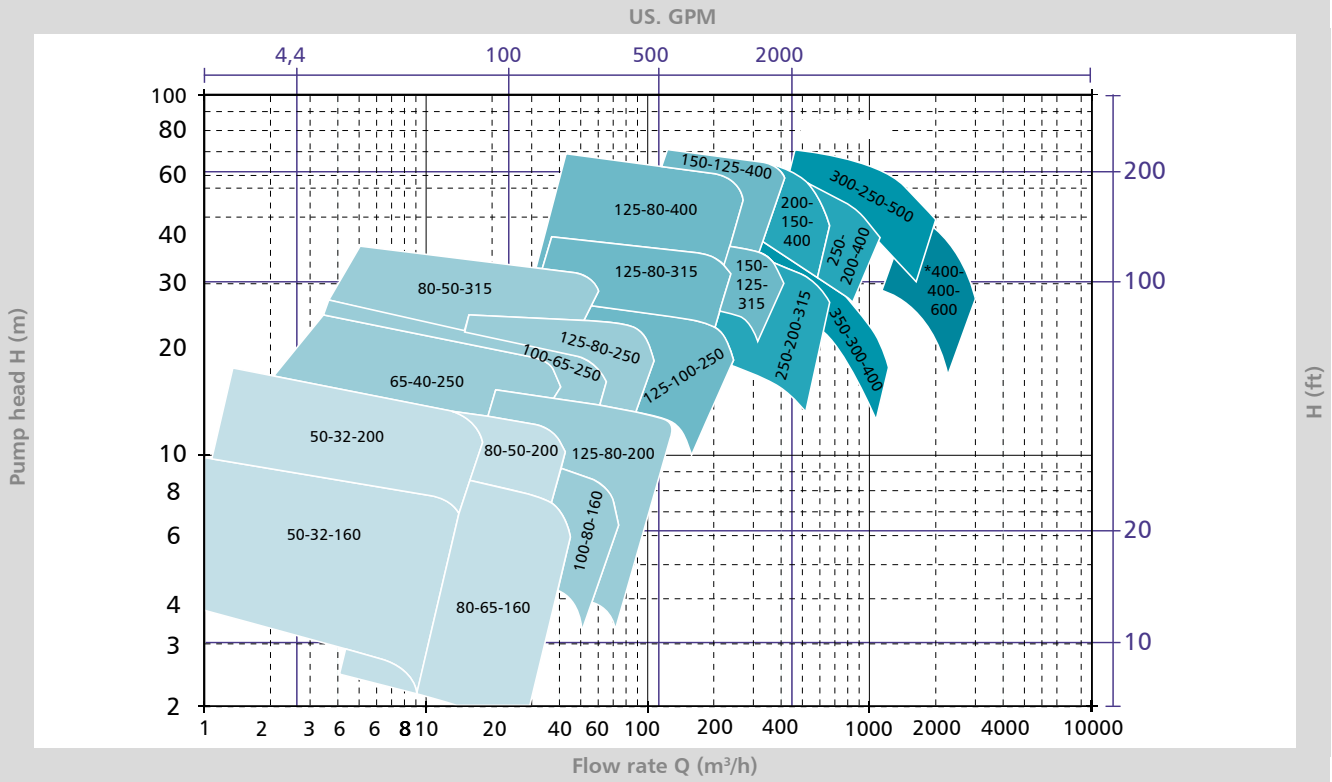

CPDR/RCNku : 50 Hz

n = 2900 /min

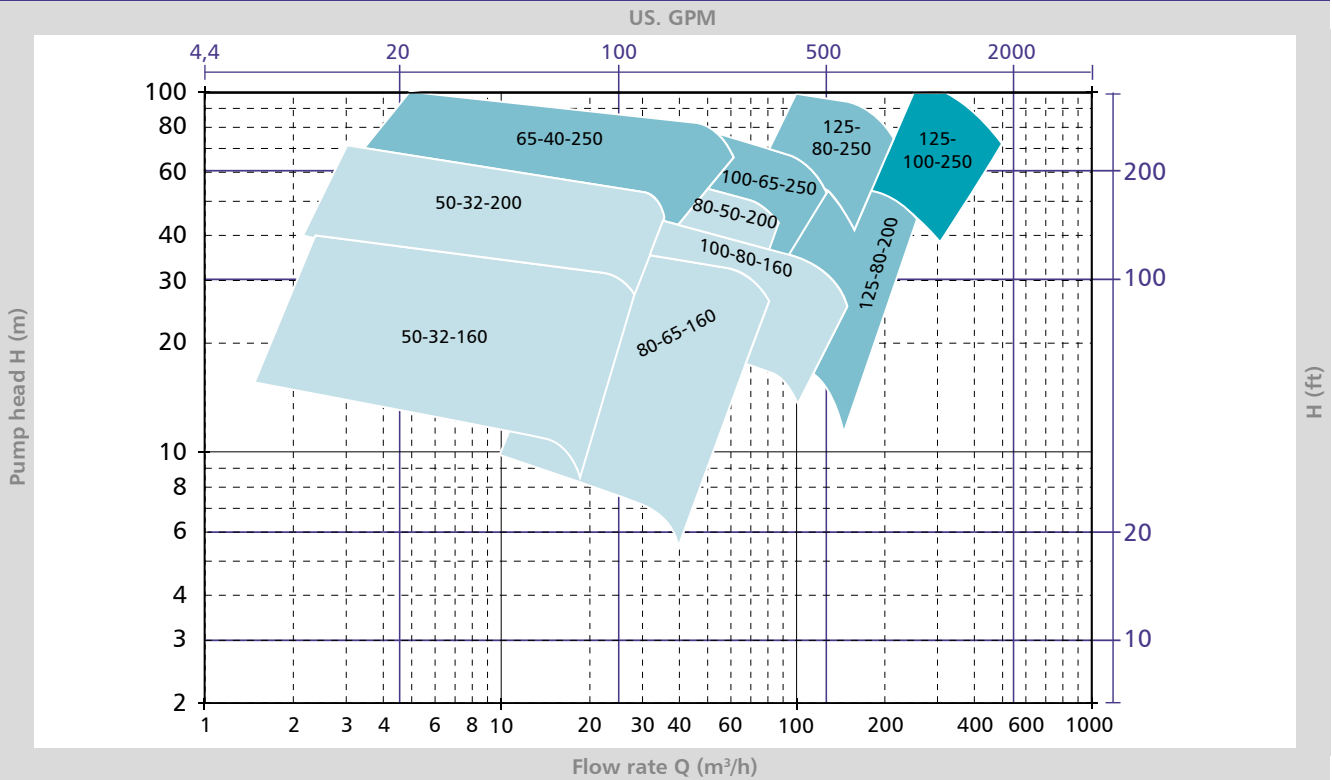

Bearing bracket 1 2 3 4 6 7

CPDR/RCNku : 60 Hz n = 1750 /min

*n = 900 /min

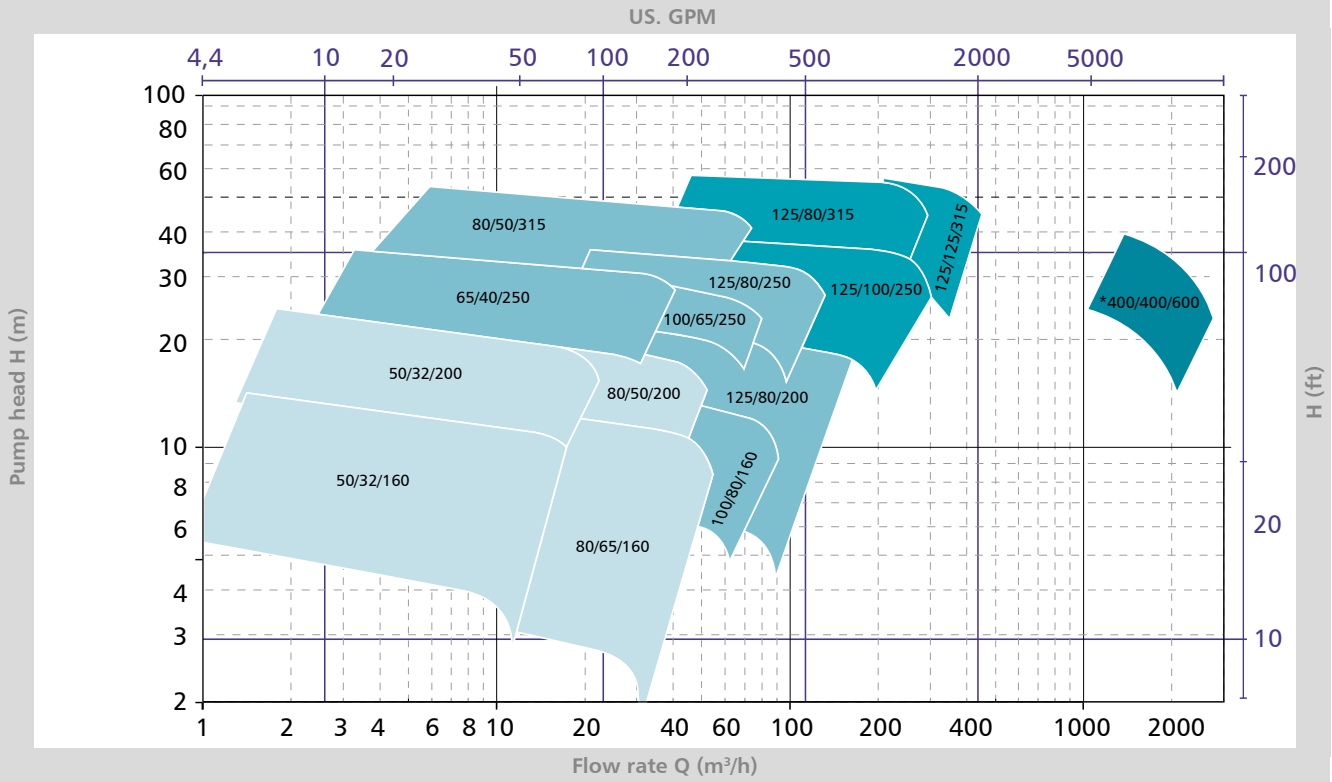

CPDR/RCNku : 60 Hz n = 3500 /min

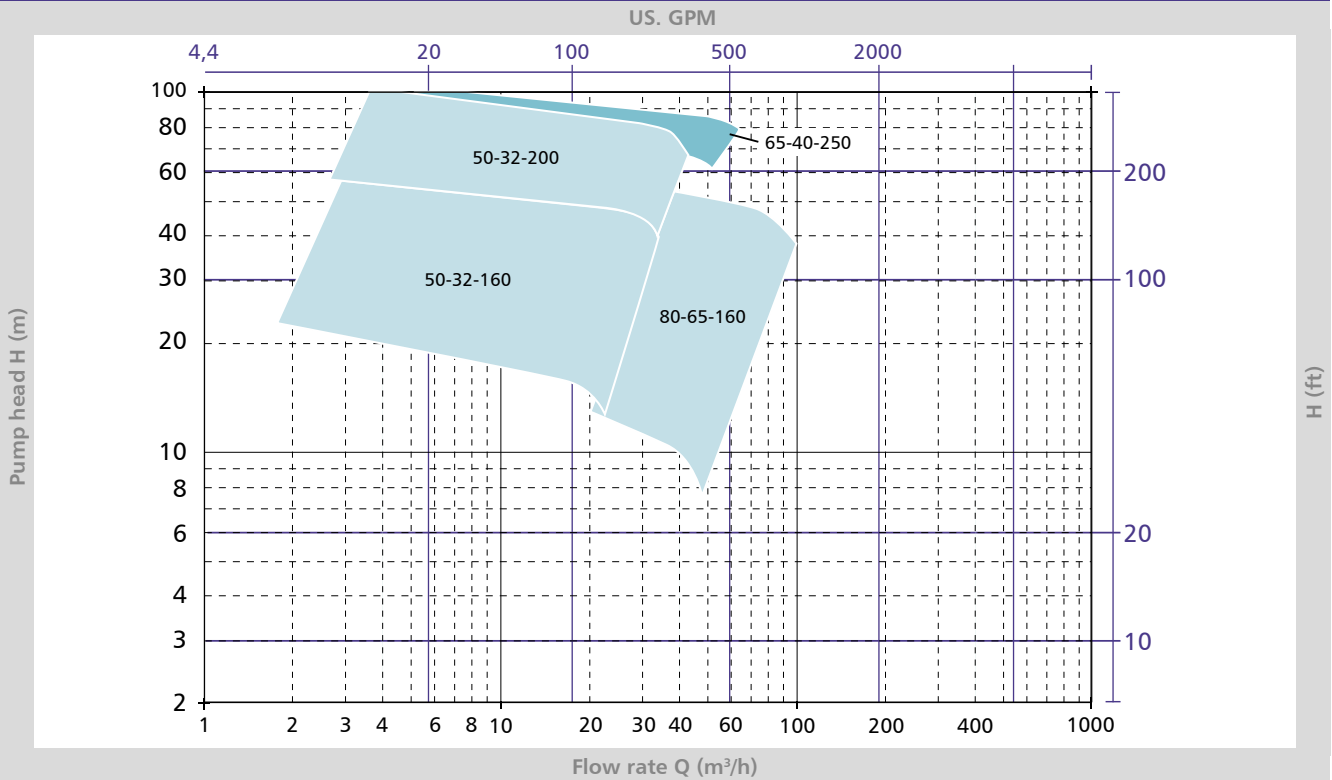



— An ITT Brand

ITT RHEINHÜTTE Pumpen GmbH
Rheingaustraße 96-98
D-65203 Wiesbaden
T +49 611 604-0
info@rheinhuette.de
www.rheinhuette.de